

Wolfstall 54-56
D-42799 Leichlingen (Germany)
Tel. +49 (0)21 74 799-0
Fax +49 (0)2174 799799
www.baero.com · E-Mail: info@baero.com

BÄRO
PERFECT RETAIL LIGHTING

Montage- und Bedienungsanleitung

Pendelleuchte Pendiro-Delphinus

Mounting and Operating Instructions

Suspended fixture Pendiro-Delphinus

Instructions de montage et d'utilisation

Luminaire suspendu Pendiro-Delphinus

Instrucciones de montaje y mantenimiento

Luminaria colgante Pendiro-Delphinus

Installazione e istruzioni per l'uso

Corpo illuminante Pendiro-Delphinus

Инструкция по монтажу и эксплуатации

Подвесной светильник Pendiro-Delphinus



Da unsere Erzeugnisse technischen Veränderungen / Optimierungen unterliegen, übernehmen wir keine Gewähr, dass alle Angaben immer aktualisiert sind. Bei Fragen steht Ihnen selbstverständlich unsere Abteilung Technik unter der Rufnummer +49 (0)2174 799-0 gerne zur Verfügung.

Sicherheitshinweise für Betrieb und Montage von Leuchten beachten



**Wichtiger Hinweis für Leuchten mit BFL und BBS-Leuchtmitteln:
Bei Flackern, Totalausfall oder sehr gelbem Licht (Lebensdauerende) sofort die Leuchte außer Betrieb setzen und das Leuchtmittel auswechseln.**

- Anschluss darf nur vom Elektriker ausgeführt werden
 - Bei Montage örtliche Vorschriften beachten
 - Die Leuchten sind anschlussfertig verdrahtet:
 - VDE 0711
 - Schutzklasse I (Schutzleiteranschluss), IP 20
 - Angaben auf Polybox und Leuchte sind zu beachten
 - Leuchtmittel, Leuchte und Polybox werden im Betrieb heiß
 - Leuchte und Polybox nicht mit Dämmmaterial abdecken
 - Bei Einbauleuchten ist ein Freiraum von mindestens 600 x 500 mm x Leuchtenhöhe einzuhalten.
 - Polyboxen nicht aufeinander legen
 - Hochspannung auf Ausgangsseite der Polybox; Lebensgefahr
 - Sind Leitungen der Polybox beschädigt, muss die Polybox ausgetauscht werden
 - Anschluss Polyboxen Netzseite:
KVG (BFL 35 W, 50 W, 100 W, BBS 35 W, 70 W, 150 W): 230 V +6% -10%, 50 Hz
EVG: 220-240 V, 50/60 Hz
 - An einem Stromkreis (mit der Absicherung B16A) dürfen maximal betrieben werden:

BFL 35 W, 50 W, 100 W (KVG)	10 Leuchten
BFL Mini 50 W (EVG)	24 Leuchten
BFL Mini 100 W (EVG)	14 Leuchten
BBS, CDM-TC 20 / 35 / 70 W KVG	10 Leuchten / EVG 14 Leuchten
BBS 150 W KVG	7 Leuchten / EVG 6 Leuchten
BBS 210 W EVG	9 Leuchten
 - Die einschaltenden Relais (Schütze) sind für Schaltströme bis 50A / 500µs auszulegen
 - Nur bei netzseitig ausgeschalteter Leuchte Leuchtmittel wechseln
 - Bei Montage oder Reparatur einer Leuchte ist der Stromkreis abzuschalten
 - Der Lampe beigelegte Sicherheitshinweise beachten
 - Nach ca. 3 – 5 Minuten erreicht das Leuchtmittel seinen vollen Lichtstrom
 - Nach Abschalten oder Netzausfall benötigt das Leuchtmittel eine Abkühlzeit bis zum Wiederzünden. Die Leuchte zum Abkühlen vom Netz trennen.
 - Das EVG schaltet bei thermischer Überlastung, bei Lampenausfall und am Lebensdauerende der Lampe ab. Vor der Wiederinbetriebnahme der Leuchte muss das EVG von der Netzspannung getrennt werden. Dies gilt auch für den Lampenwechsel
 - Die zulässige Deckenlast beachten
 - Abstandshalter auf der Leuchte nicht entfernen oder verändern
 - Beschädigte Leitungen der Leuchte dürfen nur durch vom Hersteller gelieferte Leitungen ersetzt werden
 - Anschluss nur an geeignete Vorschaltgeräte mit entsprechender Lampenleistung
 - BFL Mini-Leuchten (50/100 W) nur mit elektronischem Vorschaltgerät (EVG) betreiben.
 - BBS, CDM-TC-Leuchten mit beschädigter oder zerbrochener Glasscheibe sind außer Betrieb zu setzen bis die Scheibe ersetzt ist. Die Lampe kann zerplatzen.
 - Abstand zur angestrahlten Fläche (Aufkleber im Reflektor)

- 0,3 m bei BFL	35 / 50 / 100 W
- 0,5 m bei BBS, CDM-TC	20 / 35 / 70 W
- 1,0 m bei BBS	150 W
- 1,5 m bei BBS	210 Watt
 - Nur das für die Leuchte zugelassene Leuchtmittel verwenden. Aufkleber im Reflektor oder Typenschild beachten
 - Hinweis für 3-Phasen-Betrieb:
Vor und während Betrieb sicherstellen, dass der Neutralleiter an allen EVG-Leuchten ordnungsgemäß angeschlossen ist.
 - An Leuchten, Lichtrohren und Trägersystemen nichts anbringen, zum Beispiel Preistafeln, Deko-Elemente.
- KVG: Konventionelles Vorschaltgerät – EVG: Elektronisches Vorschaltgerät

Da unsere Erzeugnisse technischen Veränderungen / Optimierungen unterliegen, übernehmen wir keine Gewähr, dass alle Angaben immer aktualisiert sind. Bei Fragen steht Ihnen selbstverständlich unsere Abteilung Technik unter der Rufnummer +49 (0) 21 74 - 79 90 gerne zur Verfügung.

Montage- und Bedienungsanleitung

Artikel-Nr.

Lichtquelle

Pendelleuchte Pendi-Delphinus Basic

PENDIRO-DELPHINUS BASIC-MBFL
 PENDIRO-DELPHINUS BASIC-MBFL
 PENDIRO-DELPHINUS BASIC-BBS
 PENDIRO-DELPHINUS BASIC-BBS

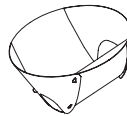

BFL Mini - 50 Watt - GBX12-1
 BFL Mini - 100 Watt - GBX12-1
 BBS - 70 Watt - G12
 BBS - 150 Watt - G12

Pendelleuchte Pendi-Delphinus Batwing

PENDIRO-DELPHINUS BATWING-MBFL
 PENDIRO-DELPHINUS BATWING-BBS
 PENDIRO-DELPHINUS BATWING-BBS

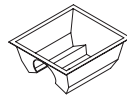

BFL Mini - 100 Watt - GBX12-1
 BLS - 70 Watt - G12
 BLS - 150 Watt - G12

Pendelleuchte Pendi-Delphinus Widewing

PENDIRO-DELPHINUS WIDEWING-MBFL
 PENDIRO-DELPHINUS WIDEWING-MBFL
 PENDIRO-DELPHINUS WIDEWING-BBS
 PENDIRO-DELPHINUS WIDEWING-BBS

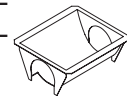

BFL Mini - 50 Watt - GBX12-1
 BFL Mini - 100 Watt - GBX12-1
 BLS - 70 Watt - G12
 BLS - 150 Watt - G12

Pendelleuchte mit Adapter

Pendelleuchte mit Deckenbaldachin

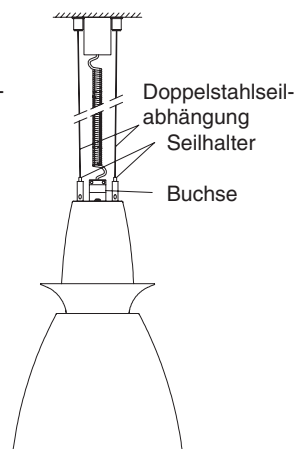
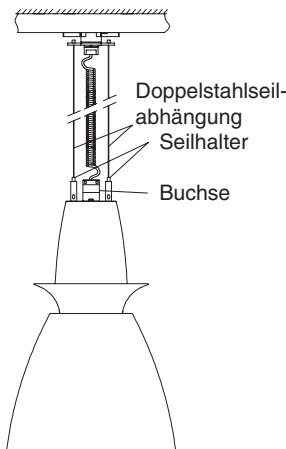

Leuchtenmontage

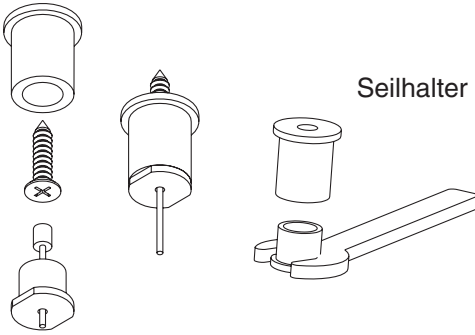

Seilhalter an Leuchte fest anschrauben
Zahnscheibe unterlegen
Schraubendreher benutzen



Höhenverstellung der Leuchte

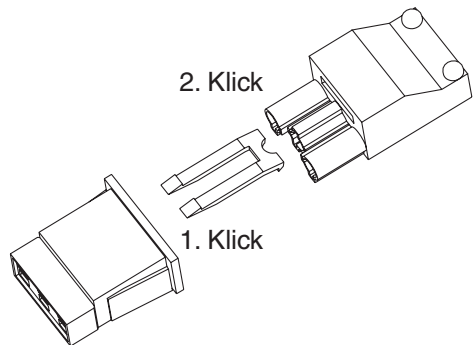
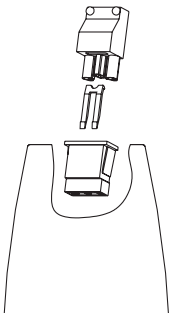
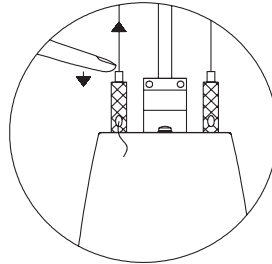

Einsetzen und Auswechseln des Leuchtmittels:

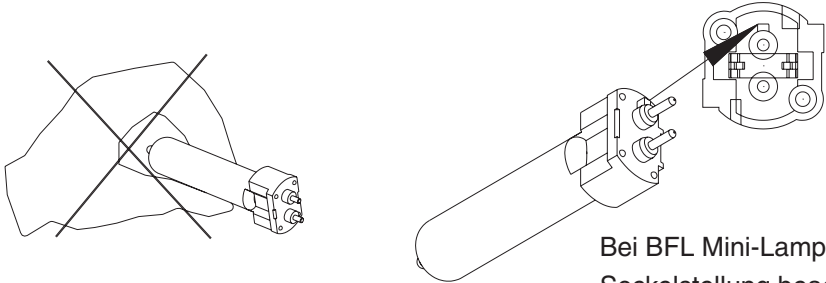
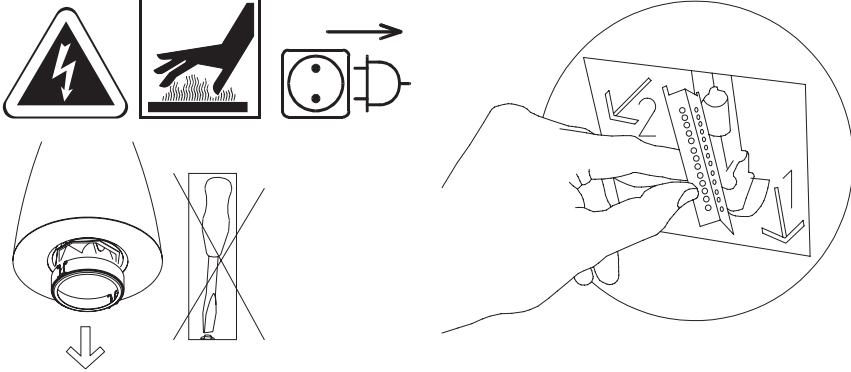

Bei BFL Mini-Lampe
Sockelstellung beachten

Ausrichten der Lampenachse mit der Doppelstahlseil- abhängung

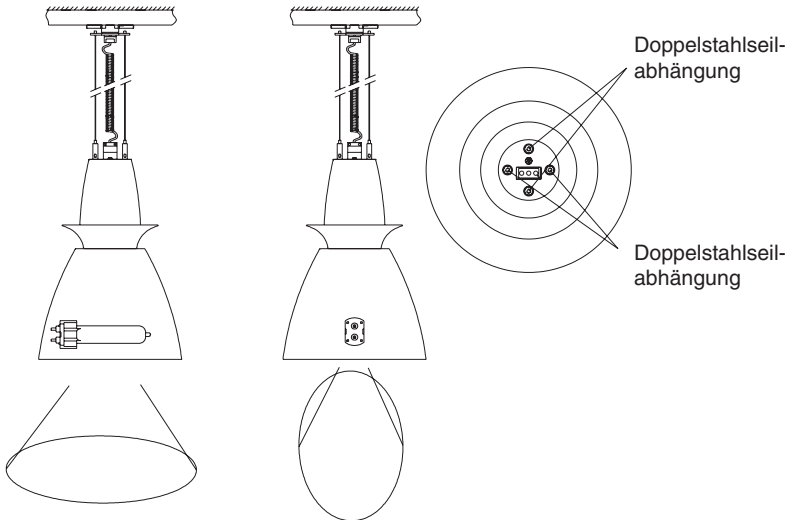

Leuchten mit Batwing-Reflektoren



Lampe quer zur beleuchteten Fläche

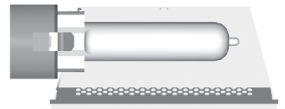
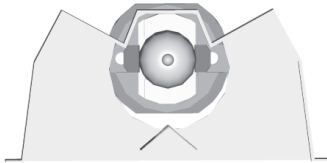
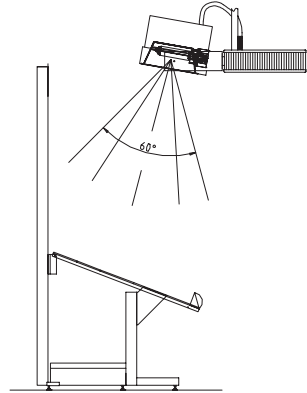
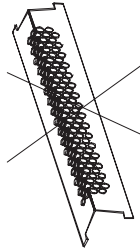
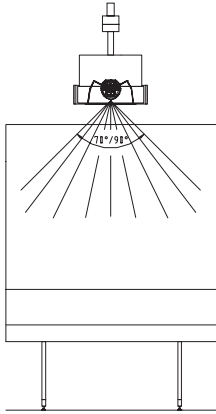

Lampe längs in Gang- und Regalrichtung

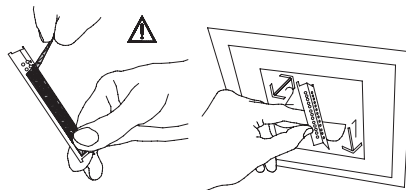
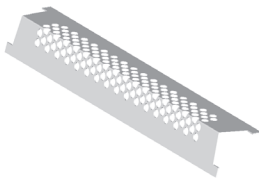
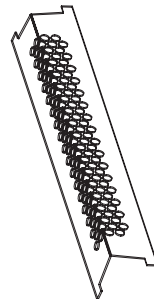
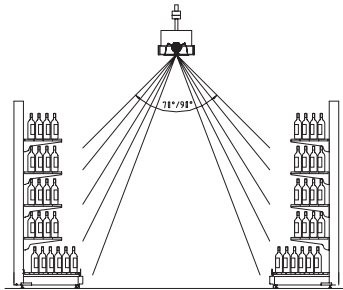

As our products are subject to technical modifications, we cannot guarantee, that all information is always up to date.

Please contact our technical department on +49 (0)2174 799-0 with any queries.

Observe safety information for operating and installing lighting fixtures.



Important information for fixtures with BFL and BBS lamps:

When the light flickers or there is a total loss of power or very yellow light (signifying end of life), the fixture should be switched off immediately and the lamp replaced

- The fixtures must only be connected by a fully qualified electrician
- Observe all safety regulations when assembling
- The fixtures are wired up ready for connection:
 - VDE 0711
 - Protection class I (protective earth connection), IP 20
- Information provided on the Polybox and fixtures must be followed
- Lamps, Fixtures and the Polybox become hot during use
- Do not put polyboxes on top of each other
- For recessed luminaires there must be clearance of at least 600 x 500 mm x luminaire height.
- Do not cover the Fixtures or Polybox with insulating material
- DANGER OF DEATH: High voltages are present at the output of the Polybox
- The Polybox must be replaced if its cables are damaged
- Polybox mains connections:
 - Conventional ballast (BFL 35 W, 50 W, 100 W, BBS 35 W, 70 W, 150 W): 230V +6% -10%, 50 Hz
 - Electronic ballast: 220-240 V, 50/60 Hz
- The following maximum number of fixtures may be operated in a circuit (with a B16A fuse):

- BFL 35 W, 50 W, 100 W (conventional ballast)	10 fixtures
- BFL Mini 50 W (electronic ballast)	24 fixtures
- BFL Mini 100 W (electronic ballast)	14 fixtures
- BBS, CDM-TC 20 / 35 / 70 W (conventional ballast)	10 fixtures / electronic ballast 14 fixtures
- BBS 150 W (conventional ballast)	7 fixtures / electronic ballast 6 fixtures
- BBS 210 W EVG	9 fixtures
- The energizing relays (contactors) must be designed for switching current of up to 50A / 500µs
- Only change lamps when mains power is disconnected
- Observe the safety instructions included with the fixtures
- The current in the fixture rises to its maximum within approx. 3 to 5 minutes
- After being switched off, or following a mains failure, the lamp must cool down before being restarted. Disconnect the power from the fixture to allow it to cool down.
- The electronic ballast is fitted with an internal overload. The ballast must be briefly disconnected from the mains supply for the overload to reset.
- The electronic ballast switches off in the event of thermal overload, when the lamp fails and when the lamp reaches the end of its life. Before the fixture is put into operation again the electronic ballast must be disconnected from the power supply. This also applies when lamps are replaced
- Do not remove or modify the fixtures spacers
- If any of the internal wires of the fixture are damaged they must only be replaced by wires supplied by the manufacturer
- Only connect to suitable ballast matching the fixture power
- BFL Mini-fixtures (50/100 W) are only for operation with an electronic ballast
- When the glass filter is damaged or broken in a BBS, CDM-TC fixture, the fixture must not be operated until the filter is replaced, because the lamp could explode.
- Minimum distance to irradiated surface (adhesive label in reflector)

- 0.3 m for BFL	35 / 50 / 100 W
- 0.5 m for BBS, CDM-TC	20 / 35 / 70 W
- 1.0 m for BBS	150 W
- 1.5 m for BBS	210 W
- Only use the lamp that is approved for the fixture. Observe the instructions on the adhesive label in the reflector or the type plate
- Information for 3-phase operation:
 - Before and during operation ensure that the neutral wire is properly connected on all fixtures with electronic ballasts
- Do not attach anything to fixtures, light tubes and support systems, for example price boards or decorations.

Wolfstall 54-56
 D-42799 Leichlingen (Germany)
 Tel. +49 (0)2174 799-0
 Fax +49 (0)2174 799799
 www.baero.com · E-Mail: info@baero.com

BAERO
 PERFECT RETAIL LIGHTING

As our products are subject to technical modifications, we cannot guarantee, that all information is always up to date.

Please contact our technical department on +49 (0) 21 74 - 79 90 with any queries.

Mounting and Operating Instructions

Article number

Light model

Suspended fixture Pendiro-Delphinus Basic

PENDIRO-DELPHINUS BASIC-MBFL

PENDIRO-DELPHINUS BASIC-MBFL

PENDIRO-DELPHINUS BASIC-BBS

PENDIRO-DELPHINUS BASIC-BBS

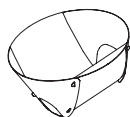

BFL Mini - 50 Watt - GBX12-1

BFL Mini - 100 Watt - GBX12-1

BBS - 70 Watt - G12

BBS - 150 Watt - G12

Suspended fixture Pendiro-Delphinus Batwing

PENDIRO-DELPHINUS BATWING-MBFL

PENDIRO-DELPHINUS BATWING-BBS

PENDIRO-DELPHINUS BATWING-BBS

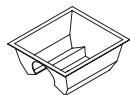

BFL Mini - 100 Watt - GBX12-1

BLS - 70 Watt - G12

BLS - 150 Watt - G12

Suspended fixture Pendiro-Delphinus Widewing

PENDIRO-DELPHINUS WIDEWING-MBFL

PENDIRO-DELPHINUS WIDEWING-MBFL

PENDIRO-DELPHINUS WIDEWING-BBS

PENDIRO-DELPHINUS WIDEWING-BBS



BFL Mini - 50 Watt - GBX12-1

BFL Mini - 100 Watt - GBX12-1

BLS - 70 Watt - G12

BLS - 150 Watt - G12

Suspended fixture with adapter

Suspended fixture with ceiling canopy

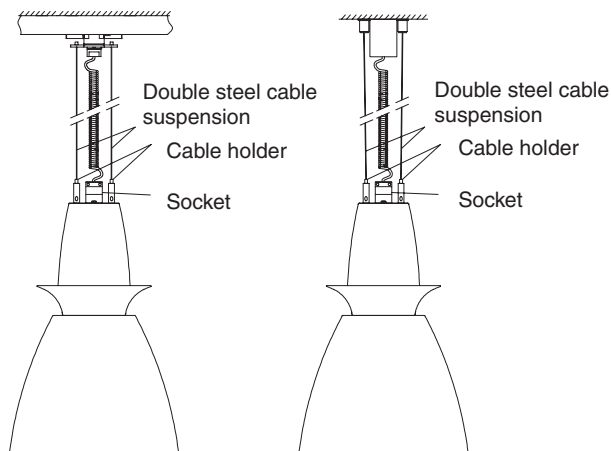

Assembly of the fixture

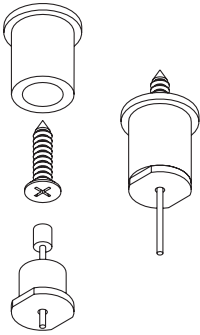

Tightly screw the cable holder to the fixture
Insert toothed washer underneath
Use a screwdriver

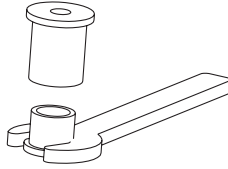

Fixture height adjustment

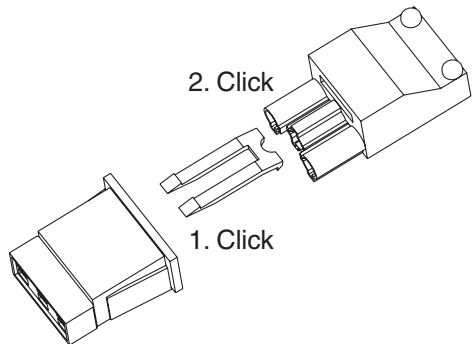
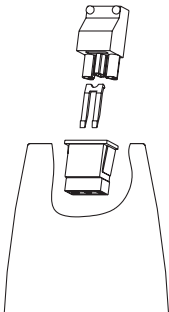
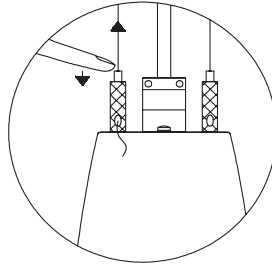

Inserting and replacing the lamp

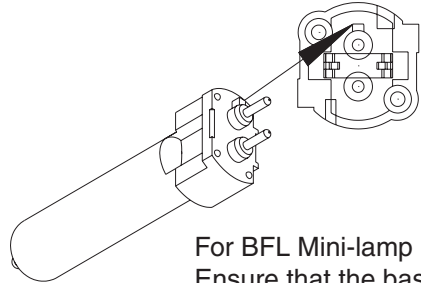
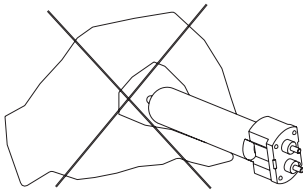
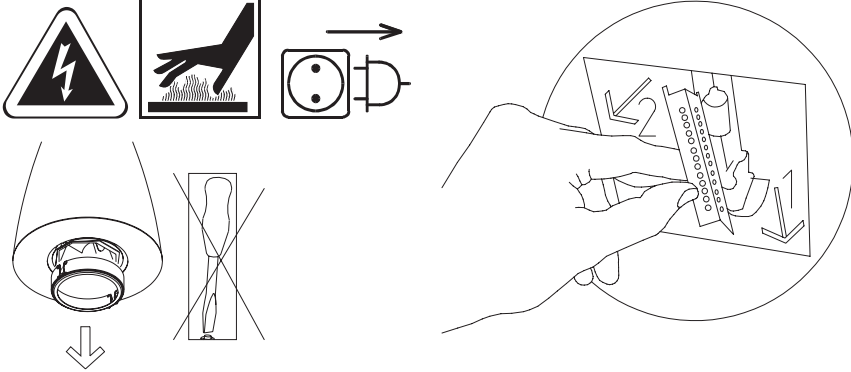

For BFL Mini-lamp
Ensure that the base is
in the right position

Aligning the lamp axis with the double steel cable suspension

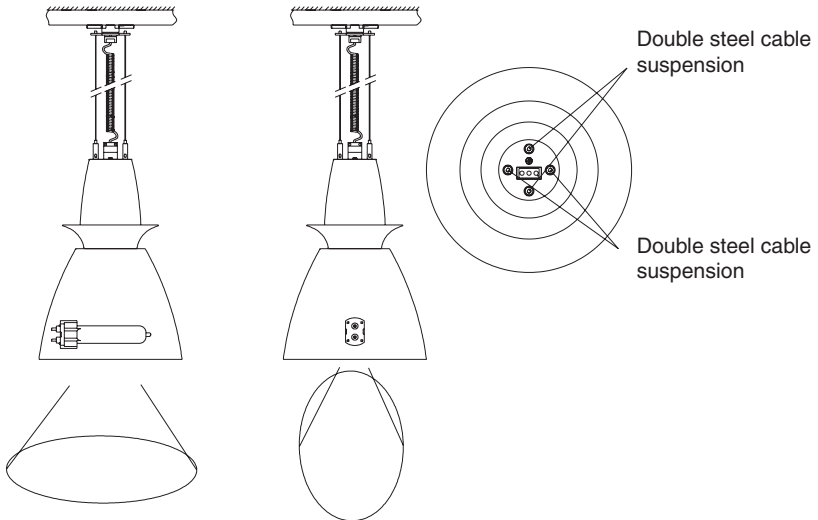

Fixtures with Batwing reflectors



Lamp at right angle to surface to be illuminated

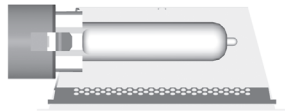
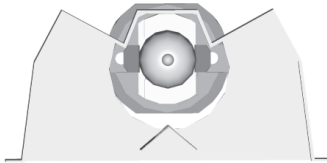
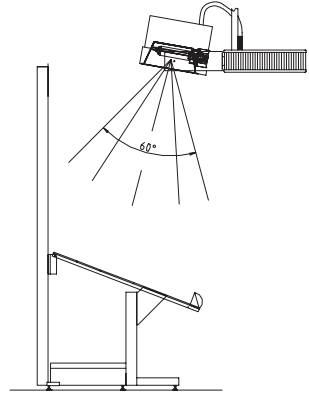
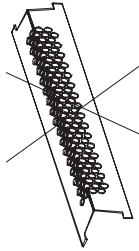
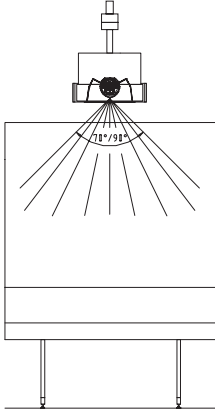

Lamp lengthwise in the direction of the aisle and shelf

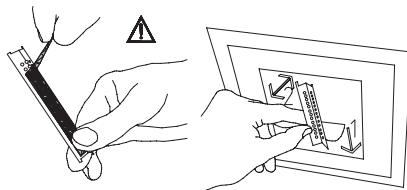
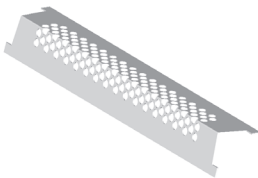
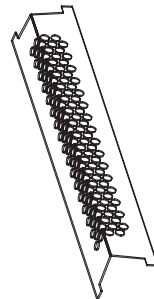
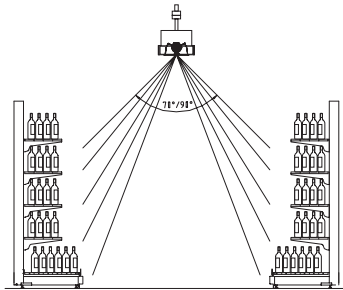

Nos produits sont susceptibles d'être modifiés techniquement à tout moment. Nous ne pouvons de ce fait garantir que toutes les informations de cette fiche technique soient à jour.

Notre service technique se tient à votre entière disposition pour toute information. +49 (0)2174 799-0

Se conformer aux consignes de sécurité pour l'exploitation et le montage de luminaires.



Remarque importante pour les luminaires équipés d'ampoules BFL et BBS :

Lors d'un vacillement de la lumière, d'un arrêt total ou lorsque la lumière devient très jaune (fin de la durée d'existence), éteindre immédiatement les luminaires et remplacer l'ampoule.

- Le raccordement doit être effectué par un électricien
- Lors du montage, respecter les consignes de sécurité spécifiques
- Les luminaires sont câblés pour raccordement
 - VDE 0711
 - Classe de protection I (conducteur de protection), IP 20
- Respecter les données figurant sur le Polybox et le luminaire
- Lors du fonctionnement, les lampes, luminaires et Polybox chauffent
- Ne pas couvrir les luminaires et les Polybox avec du matériau isolant
- Pour les luminaires encastrables, il faut respecter un intervalle de 600 x 500 mm x hauteur du luminaire.
- Ne pas poser les platines de commande l'une sur l'autre
- Haute tension à la sortie du Polybox; danger de mort
- Si les câbles du Polybox sont endommagés, échanger le Polybox
- Raccordement du Polybox au réseau:
ballast conventionnel (BFL 35 W, 50 W, 100 W, BBS 35 W, 70 W, 150 W): 230 V +6% -10%, 50 Hz
ballast électronique: 220-240 V, 50/60 Hz
- Ne faire fonctionner sur un circuit (avec la protection par fusible B16A) qu'au maximum :
 - BFL 35 W, 50 W, 100 W (ballast conventionnel) 10 luminaires
 - BFL Mini 50 W (ballast électronique) 24 luminaires
 - BFL Mini 100 W (ballast électronique) 14 luminaires
 - BBS, CDM-TC 20 / 35 / 70 W (ballast conventionnel) 10 luminaires /
ballast électronique 14 luminaires
 - BBS 150 W (ballast conventionnel) 7 luminaires /
ballast électronique 6 luminaires
 - BBS 210 W EVG 9 luminaires
- Les relais (contacteurs-interrupteurs) activés doivent être conçus pour des courants de commutation de jusqu'à 50 A / 500 µs
- Ne remplacer la lampe qu'avec un luminaire hors tension
- Observer les consignes de sécurité accompagnant la lampe
- La lampe atteint son flux lumineux maximal après 3 à 5 minutes
- Après avoir éteint ou en cas de panne de secteur, la lampe doit refroidir avant un rallumage. Déconnecter le luminaire pendant le refroidissement
- Couper momentanément le bloc d'alimentation électronique du réseau après avoir déclencher le dispositif de sécurité.
- Le ballast électronique s'éteint en cas de surcharge thermique ou si la lampe lâche ou si la lampe atteint sa fin de vie. Avant toute remise en service de l'installation, le ballast électronique doit être coupé de l'alimentation. Il en est de même pour le remplacement de lampes
- Ne pas enlever ou modifier la protection du luminaire
- Les câbles endommagés du luminaire ne peuvent être remplacés que par des câbles fournis par le fabricant
- Raccordement exclusivement au ballast adéquat avec puissance de lampe correspondante
- Utiliser les lampes BFL Mini (50/100 W) uniquement avec des Polybox électroniques
- Les luminaires avec filtre endommagé ou cassé seront mis hors service jusqu'au remplacement de celui-ci. La lampe peut exploser
- Distance par rapport à la surface éclairée (étiquette sur réflecteur)
 - 0,3 m pour BFL 35 / 50 / 100 W
 - 0,5 m pour BBS, CDM-TC 20 / 35 / 70 W
 - 1,0 m pour BBS 150 W
 - 1,5 m pour BBBS 210 W
- N'utiliser que des lampes correspondant au luminaire. Observer l'étiquette sur le réflecteur ou la plaque d'identification
- Remarque pour le fonctionnement triphasé :
Vérifier avant et pendant l'utilisation que le conducteur neutre est raccordé en bonne et due forme à tous les luminaires à bloc d'alimentation électronique.
- Ne rien attacher d'aucune manière sur les luminaires, structures et supports comme par exemple tableaux de prix ou décorations.

Nos produits sont susceptibles d'être modifiés techniquement à tout moment. Nous ne pouvons de ce fait garantir que toutes les informations de cette fiche technique soient à jour.

Notre service technique se tient à votre entière disposition pour toute information. +49 (0) 21 74 - 79 90

Instructions de montage et d'utilisation

Article no.

Type de luminaire

Luminaire suspendu Pendiro-Delphinus Basic

PENDIRO-DELPHINUS BASIC-MBFL

PENDIRO-DELPHINUS BASIC-MBFL

PENDIRO-DELPHINUS BASIC-BBS

PENDIRO-DELPHINUS BASIC-BBS

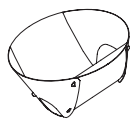

BFL Mini - 50 Watt - GBX12-1

BFL Mini - 100 Watt - GBX12-1

BBS - 70 Watt - G12

BBS - 150 Watt - G12

Luminaire suspendu Pendiro-Delphinus Batwing

PENDIRO-DELPHINUS BATWING-MBFL

PENDIRO-DELPHINUS BATWING-BBS

PENDIRO-DELPHINUS BATWING-BBS

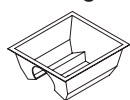

BFL Mini - 100 Watt - GBX12-1

BLS - 70 Watt - G12

BLS - 150 Watt - G12

Suspended fixture Pendiro-Delphinus Widewing

PENDIRO-DELPHINUS WIDEWING-MBFL

PENDIRO-DELPHINUS WIDEWING-MBFL

PENDIRO-DELPHINUS WIDEWING-BBS

PENDIRO-DELPHINUS WIDEWING-BBS



BFL Mini - 50 Watt - GBX12-1

BFL Mini - 100 Watt - GBX12-1

BLS - 70 Watt - G12

BLS - 150 Watt - G12

Luminaire suspendu avec adaptateur universel

Luminaire suspendu avec baldaquin

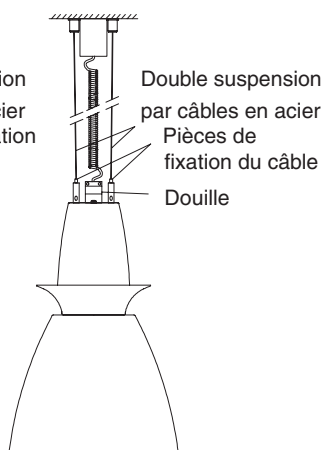
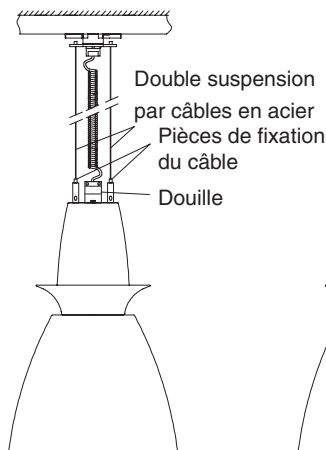

Montage du luminaire

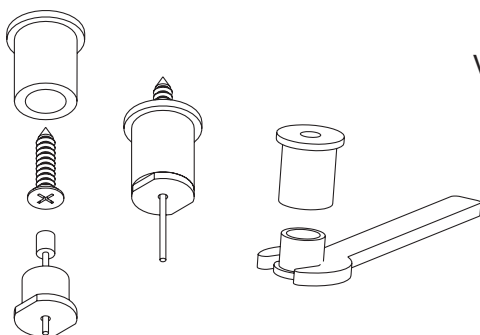

Visser complètement la pièce
de fixation au luminaire
Insérer une rondelle
Utiliser un tournevis



Réglage en hauteur du luminaire

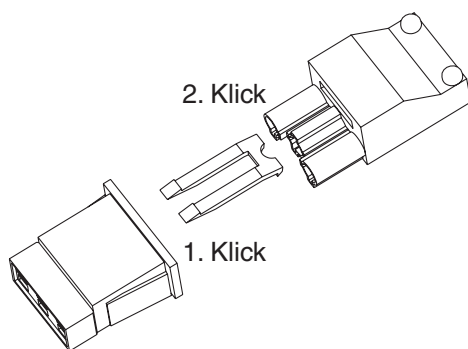
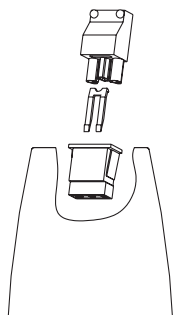
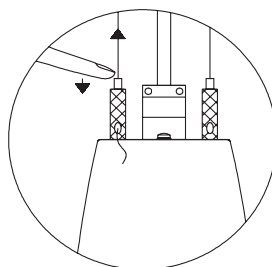

Pose et remplacement de la lampe

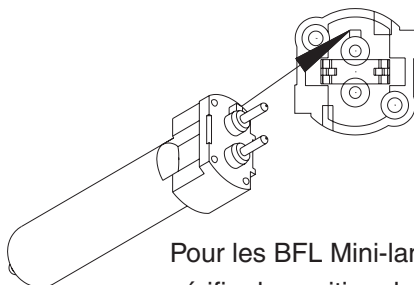
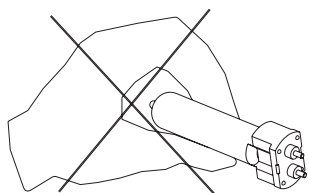
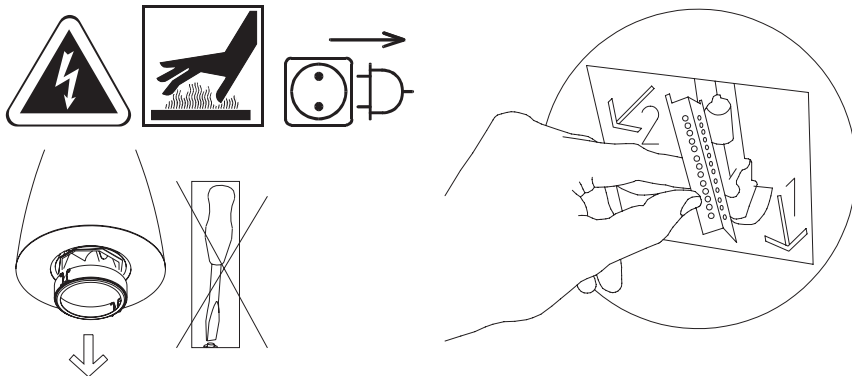

Pour les BFL Mini-lampes,
vérifier la position du socle

Orientation de l'axe du luminaire à l'aide de la double suspension par câbles en acier

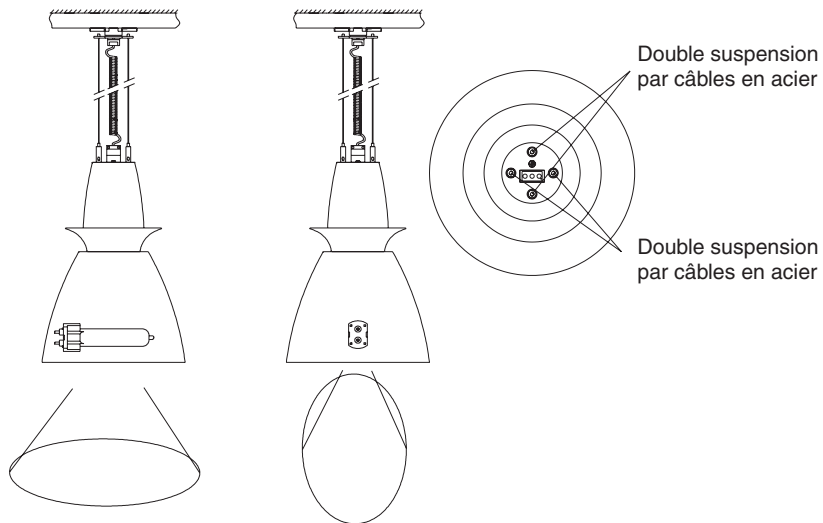

Luminaires avec réflecteurs de forme « Batwing »



Lampe montée de manière perpendiculaire à la surface à éclairer

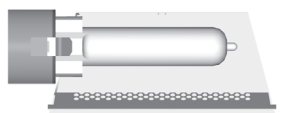
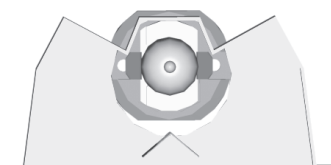
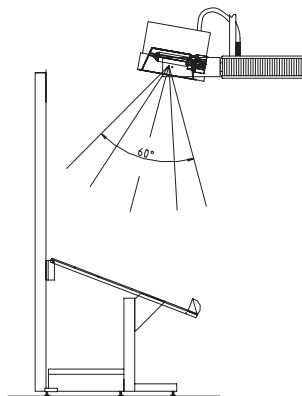
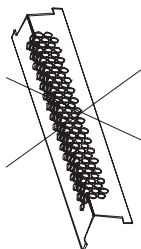
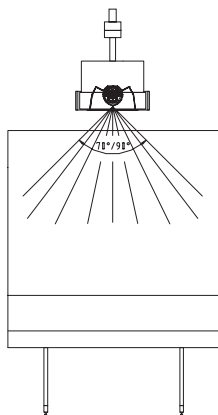

Lampe montée dans l'axe du couloir et des rayons

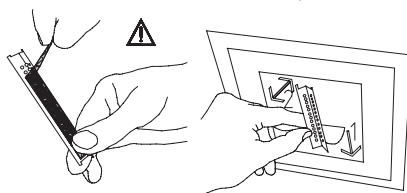
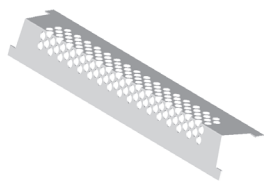
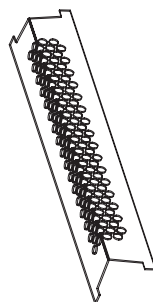
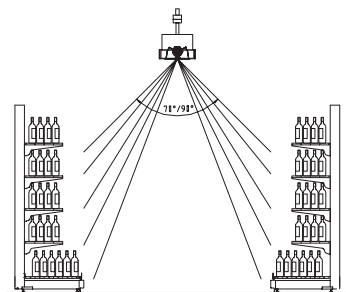

Nuestros productos están sujetos a cambios técnicos u optimizaciones por ello no nos responsabilizamos que toda la información técnica este actualizada. En caso de preguntas, no vacile en llamar a nuestro Dpto. Técnico bajo el número de teléfono +49 (0)2174 799-0.

Obsérvense las advertencias de seguridad durante la operación y el montaje de las luminarias.



Información importante para luminarias con lámpara BFL y BBS:

En caso de que la lámpara parpadee, pierda totalmente su potencia o dé una luz muy amarilla (final de la vida lámpara), des conectar la luminaria enseguida de la red y sustituir la lámpara.

- La conexión sólo debe ser realizada por un electricista
- Cumpla las disposiciones locales durante el montaje
- Las lámparas se entregan con los cables listos para su conexión:
 - VDE 0711
 - Clase de protección I (Conexión del conductor protector), IP 20
- Tenga en cuenta los datos que figuran en la Polybox y en la luminaria
- La lámpara, la luminaria y la Polybox se calientan cuando están en funcionamiento
- No cubra la luminaria ni la Polybox con material aislante
- Al instalar luminarias empotradas debe mantenerse una separación mínima de 600 x 500 mm x altura de la luminaria.
- No desmontar el equipo electrónico
- Alta tensión en la salida de la Polybox: Peligro de muerte
- Si los cables de la Polybox están dañados, reemplace esta última
- Conexión de las Polybox, lado de la red:
equipo convencional (BFL 35 W, 50 W, 100 W, BBS 35 W, 70 W, 150 W):
230 V +6% -10%, 50Hz
equipo electrónico: 220-240 V, 50/60 Hz
- En un circuito (con protección por fusible B16A) pueden conectarse como máximo:

- BFL 35 W, 50 W, 100 W (equipo convencional):	10 luminarias
- BFL Mini 50 W (equipo electrónico):	24 luminarias
- BFL Mini 100 W (equipo electrónico):	14 luminarias
- BBS, CDM-TC 20 / 35 / 70 W (equipo convencional):	10 luminarias / equipo electrónico: 14 luminarias
- BBS 150 W (equipo convencional):	7 luminarias / equipo electrónico: 6 luminarias
- BBS 210 W EVG	9 luminarias
- Los relés conectados (contactores) tienen que dimensionarse para intensidades de conmutación de hasta 50A / 500 µs
- Sólo cambie las lámparas con la luminaria desconectada de la red
- Cumpla las instrucciones de seguridad adjuntas a la luminaria
- La lámpara alcanza su pleno flujo luminoso transcurridos entre 3 y 5 minutos.
- Después del apagado o de un corte de corriente, la lámpara requiere un período de enfriamiento para volver a encenderse. Desconecte la luminaria de la red para que se enfríe.
- El equipo electrónico ha de ser desconectado de la red una vez halla funcionado el circuito interno de seguridad
- El equipo electrónico se desconecta en caso de sobrecarga térmica, fallo de una de las bombillas y al término de la vida útil de las mismas. Antes de activar de nuevo la lámpara deberá desconectarse de la red el equipo electrónico. Lo mismo debe tenerse en cuenta al efectuar un cambio de bombillas
- No retire ni modifique los espaciadores de la luminaria
- Sustituya los cables dañados de la luminaria únicamente por cables originales del fabricante
- Realice la conexión únicamente a equipos de la capacidad adecuada
- Luminarias BFL Mini (50/100 W) solo funcionan con equipos electrónicos
- No utilice luminarias con cristales dañados o rotos hasta sustituirlos. La lámpara puede explotar.
- Distancia mínima a la superficie irradiada (Etiqueta en el reflector)

- 0,3 m con BFL	35 / 50 / 100 W
- 0,5 m con BBS, CDM-TC	20 / 35 / 70 W
- 1,0 m con BBS	150 W
- 1,5 m con BBS	210 W
- Utilice únicamente las lámparas autorizadas para la luminaria. Consulte la etiqueta colocada sobre el reflector o la placa de tipo.
- Información para el uso en tres fases:
Antes y durante el uso asegurarse que el neutro este conectado a todos los equipos según la normativa.
- No colgar ni apoyar elementos extraños de las luminarias ni de los sistemas suspendidos.

Nuestros productos están sujetos a cambios técnicos u optimizaciones por ello no nos responsabilizamos que toda la información técnica este actualizada. En caso de preguntas, no vacile en llamar a nuestro Dpto. Técnico bajo el número de teléfono +49 (0) 21 74 - 79 90.

Instrucciones de montaje y mantenimiento

Nº de ref.

Tipo de lámpara

Luminaria colgante Pendiro-Delphinus Basic

PENDIRO-DELPHINUS BASIC-MBFL
 PENDIRO-DELPHINUS BASIC-MBFL
 PENDIRO-DELPHINUS BASIC-BBS
 PENDIRO-DELPHINUS BASIC-BBS

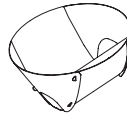

BFL Mini - 50 Watt - GBX12-1
 BFL Mini - 100 Watt - GBX12-1
 BBS - 70 Watt - G12
 BBS - 150 Watt - G12

Luminaria colgante Pendiro-Delphinus Batwing

PENDIRO-DELPHINUS BATWING-MBFL
 PENDIRO-DELPHINUS BATWING-BBS
 PENDIRO-DELPHINUS BATWING-BBS

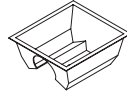

BFL Mini - 100 Watt - GBX12-1
 BLS - 70 Watt - G12
 BLS - 150 Watt - G12

Luminaria colgante Pendiro-Delphinus Widewing

PENDIRO-DELPHINUS WIDEWING-MBFL
 PENDIRO-DELPHINUS WIDEWING-MBFL
 PENDIRO-DELPHINUS WIDEWING-BBS
 PENDIRO-DELPHINUS WIDEWING-BBS

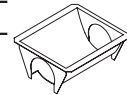

BFL Mini - 50 Watt - GBX12-1
 BFL Mini - 100 Watt - GBX12-1
 BLS - 70 Watt - G12
 BLS - 150 Watt - G12

Luminaria colgante con adaptor

Luminaria colgante con peana de techo

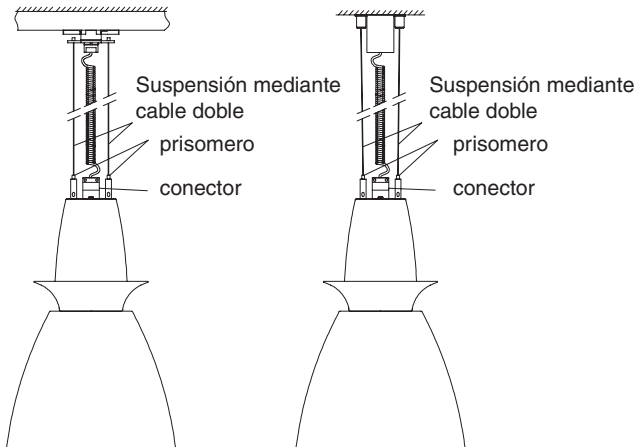

Conexión de la luminaria

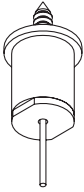
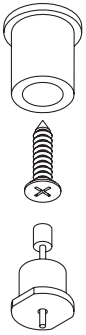

Artonillar firmemente el prisomero en la luminaria
Colocar debajo una arandela dentada
Utilizar un destornillador

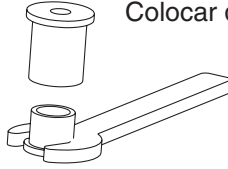

Ajuste en altura de la luminaria

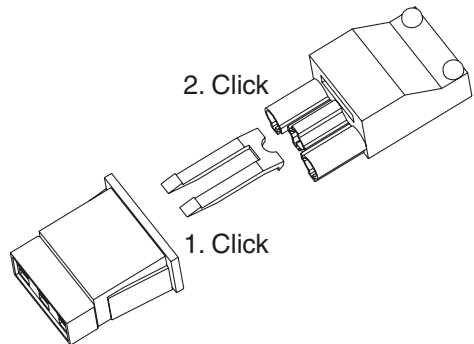
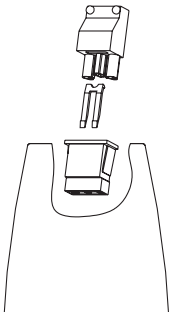
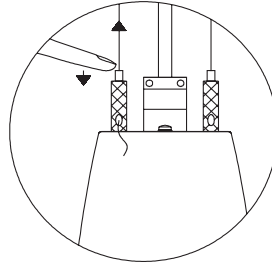

Colocación y recambio de la lámpara

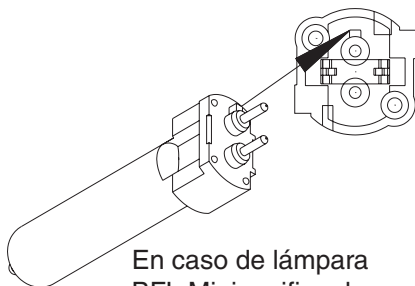
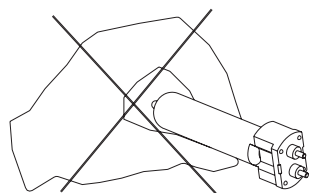
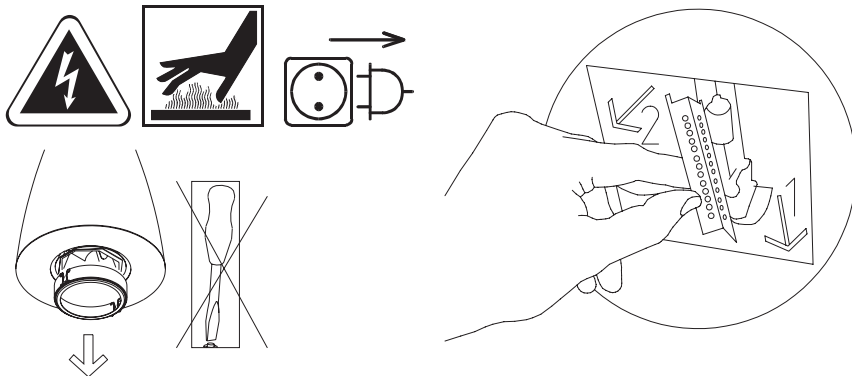

En caso de lámpara BFL Mini verificar la posición

Alineación del eje de lámpara por la suspensión de cable de acero doble

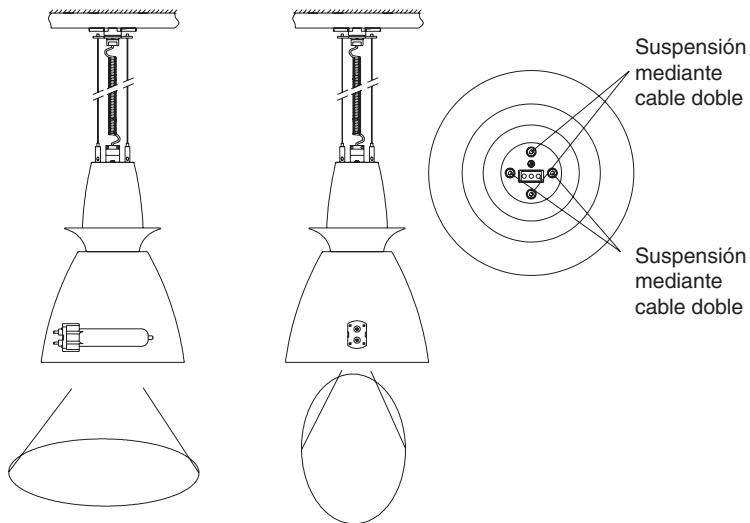

Luminarias con reflectores Batwing



Lámpara en posición transversal a la superficie a iluminar

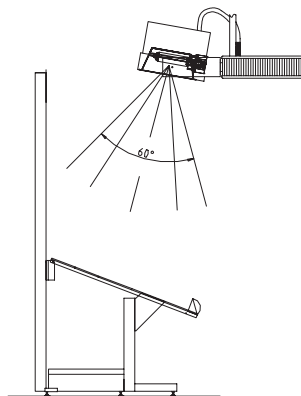
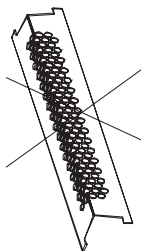
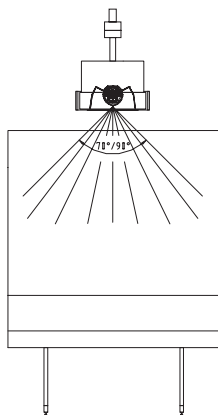

Lámpara en posición longitudinal al pasillo o al estante

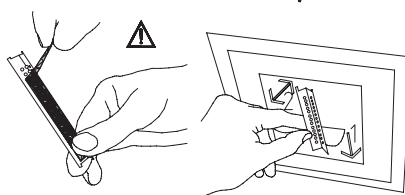
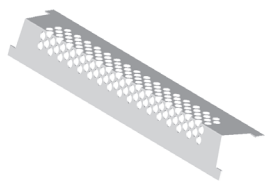
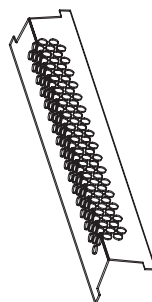
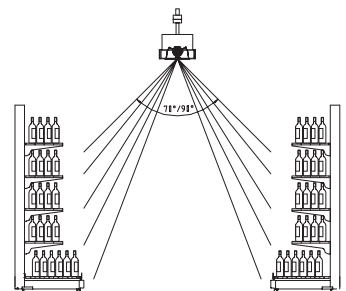

I nostri prodotti sono soggetti a modifiche / migliorie tecniche costanti e pertanto non possiamo garantire che tutti i dati forniti siano stati aggiornati. Il nostro Ufficio Tecnico - raggiungibile al numero di telefono +49 (0)2174 799-0 è a Vostra disposizione per eventuali domande in merito.

Osservare le avvertenze per la sicurezza durante il funzionamento ed il montaggio dei fari



Nota importante per fari dotati di lampade BFL e BSL: in caso di sfarfallamenti, spegnimento improvviso o luce molto giallastra (termine ciclo di vita) spegnere immediatamente il faro e sostituire la lampada.

- L'allacciamento deve essere effettuato solo da un elettricista
- Durante il montaggio osservare le norme locali
- I fari sono pronti per l'allacciamento e dotati di cavi:
 - VDE 0711
 - Classe di protezione I (collegamento a massa), IP 20
- Osservare le indicazioni riportate sul polybox e sul faro
- Durante il funzionamento la lampada, il faro e il polybox si surriscaldano
- Non posizionare i polybox a distanza l'uno dall'altro
- Con fari da incasso rispettare uno spazio libero di almeno 600 x 500mm x altezza faro.
- Dal polybox esce dell'alta tensione; pericolo di morte
- Se i cavi del polybox sono danneggiati bisogna sostituire il polybox
- Allacciamento dei polybox, lato rete:
KVG (BFL 50 W, 100 W, BBS 35 W, 70 W, 150 W): 230 V +6% -10%, 50 Hz
EVG: 220-240 V, 50/60 Hz
- Su un circuito elettrico (con il fusibile B16A) possono operare al massimo:
 - BFL 35 W, 50 W, 100 W (KVG) 10 fari
 - BFL Mini 50 W (EVG) 24 fari
 - BFL Mini 100 W (EVG) 14 fari
 - BBS, CDM-TC 20 / 35 / 70 W (KVG) 10 fari/ EVG 14 fari
 - BBS 150 W (KVG) 7 fari/ EVG 6 fari
 - BBS 210 W EVG 9 fari
- I relè di commutazione (teleruttori) devono essere dimensionati per correnti d'inserzione fino a 50A /500 µs
- Sostituire le lampade solo quando i fari non sono più allacciati alla rete elettrica
- Osservare le indicazioni sulla sicurezza contenute nella confezione del faro
- La lampada raggiunge il pieno flusso luminoso dopo ca. 3-5 minuti
- Dopo lo spegnimento o interruzione dell'erogazione di corrente la lampada richiede un periodo di raffreddamento prima di poter accendere nuovamente il faro. Per il raffreddamento staccare il faro dalla rete elettrica.
- Dopo che è scattato il fusibile interno bisogna separare per breve tempo l'unità ausiliaria elettronica dall'alimentazione di corrente
- L'alimentatore elettronico si disattiva in caso di sovraccarico termico, spegnimento delle lampade e al termine della durata di vita delle lampade. Prima di riaccendere il faro staccare l'alimentatore dalla tensione di rete. Procedere allo stesso modo anche in caso di sostituzione delle lampade
- Non rimuovere o spostare il distanziatore sul faro
- Eventuali cavi danneggiati del faro possono essere sostituiti solo con cavi forniti dal produttore.
- Allacciare solo ad un ballast adatto con potenza corrispondente a quella del faro.
- Far funzionare le lampade mini BFL (50/100 W) solo con ballast elettronico (EVG)
- I fari con copertura anteriore in vetro danneggiata o rotta devono essere spenti e tenuti spenti fino alla sostituzione della copertura. La lampada potrebbe scoppiare.
- Distanza dalla superficie illuminata (vedere etichetta nel riflettore)
 - 0,3 m per lampade BFL 35 / 50 / 100 W
 - 0,5 m per lampade BBS, CDM-TC 20 / 35 / 70 W
 - 1,0 m per lampade BBS 150 W
 - 1,5 m per lampade BBS 210 W
- Utilizzare solo lampade omologate per questo tipo di fari. Vedere l'etichetta nel riflettore o la targhetta con il tipo di modello
- Nota per il funzionamento trifase: prima e durante il funzionamento assicurarsi che il conduttore neutro sia allacciato correttamente a tutte le unità ausiliare elettroniche (polybox) dei fari.
- Non applicare nulla, p.e. tabelle con i prezzi, elementi decorativi ecc., su fari, strutture tubolari e sistemi portanti.

KVG: Ballast tradizionale (elettromeccanico) – EVG: Ballast elettronico

I nostri prodotti sono soggetti a modifiche / migliorie tecniche costanti e pertanto non possiamo garantire che tutti i dati forniti siano stati aggiornati. Il nostro Ufficio Tecnico - raggiungibile al numero di telefono +49 (0) 21 74 - 79 90 è a Vostra disposizione per eventuali domande in merito.

Installazione e istruzioni per l'uso

No. articolo

Modello faro

Corpo illuminante Pendiro-Delphinus Basic

PENDIRO-DELPHINUS BASIC-MBFL

PENDIRO-DELPHINUS BASIC-MBFL

PENDIRO-DELPHINUS BASIC-BBS

PENDIRO-DELPHINUS BASIC-BBS

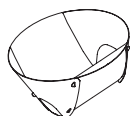

BFL Mini - 50 Watt - GBX12-1

BFL Mini - 100 Watt - GBX12-1

BBS - 70 Watt - G12

BBS - 150 Watt - G12

Corpo illuminante Pendiro-Delphinus Batwing

PENDIRO-DELPHINUS BATWING-MBFL

PENDIRO-DELPHINUS BATWING-BBS

PENDIRO-DELPHINUS BATWING-BBS

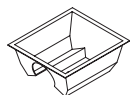

BFL Mini - 100 Watt - GBX12-1

BLS - 70 Watt - G12

BLS - 150 Watt - G12

Corpo illuminante Pendiro-Delphinus Widewing

PENDIRO-DELPHINUS WIDEWING-MBFL

PENDIRO-DELPHINUS WIDEWING-MBFL

PENDIRO-DELPHINUS WIDEWING-BBS

PENDIRO-DELPHINUS WIDEWING-BBS



BFL Mini - 50 Watt - GBX12-1

BFL Mini - 100 Watt - GBX12-1

BLS - 70 Watt - G12

BLS - 150 Watt - G12

Corpo illuminante a sospensione
 con adattatore

Corpo illuminante a sospensione
 con bicchierino copricavo

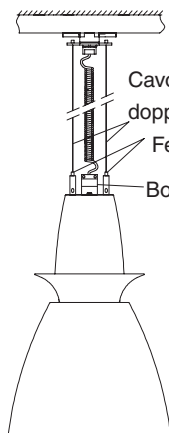

Cavo di sospensione
 doppio in acciaio
 Fermacavo
 Boccola

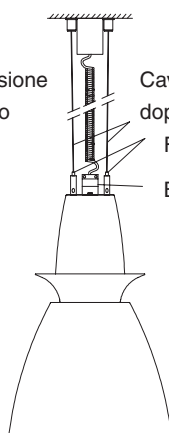

Cavo di sospensione
 doppio in acciaio
 Fermacavo
 Boccola

Montaggio corpo illuminante

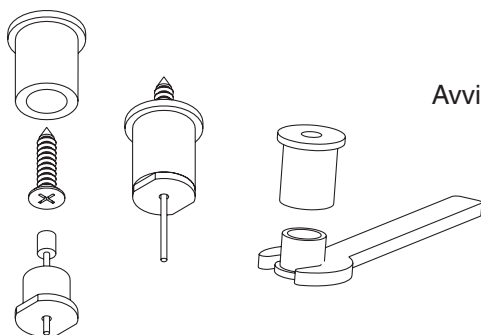

Avvitare saldamente il fermacavo
al corpo illuminante



Regolazione in altezza
del corpo illuminante

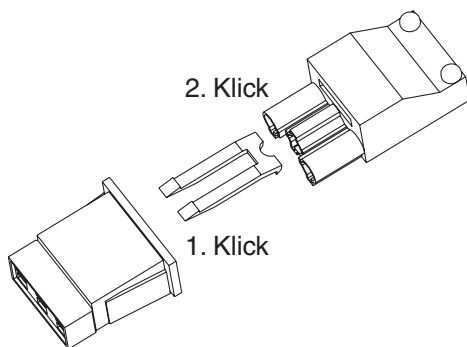
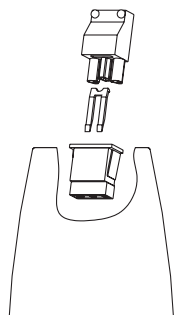
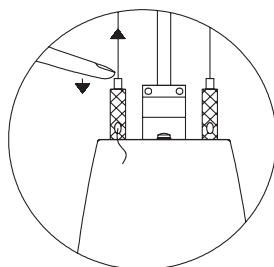

Inserimento e sostituzione della lampada

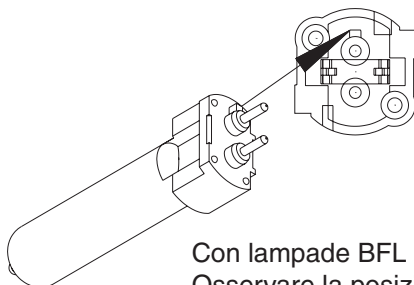
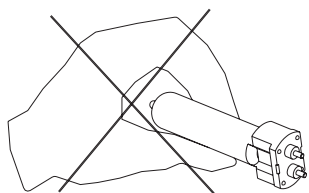
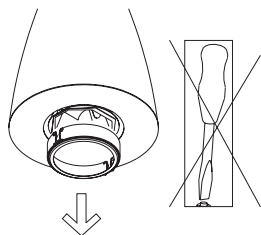
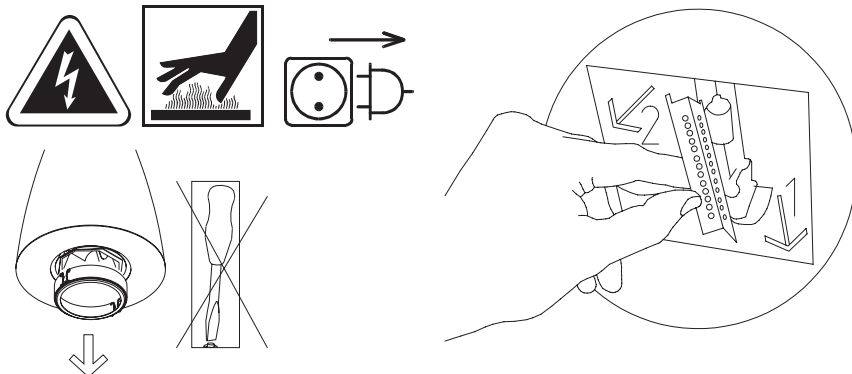

Con lampade BFL mini
Osservare la posizione
dell'attacco

Centrare l'asse della lampada rispetto ai cavi di sospensione in acciaio

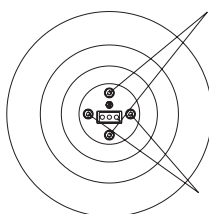
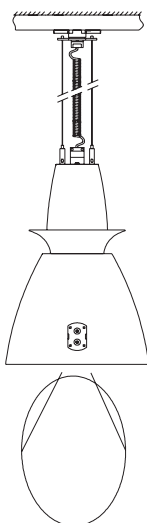
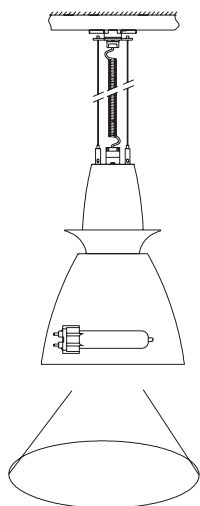

Cavo di sospen-
sione
doppio in acciaio

Cavo di sospen-
sione
doppio in acciaio

Fari con riflettore batwing



Faro posto trasversalmente rispetto alla superficie da illuminare

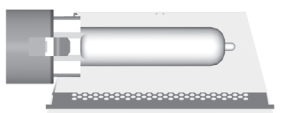
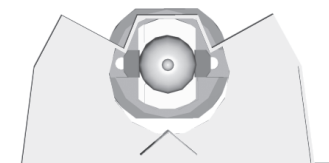
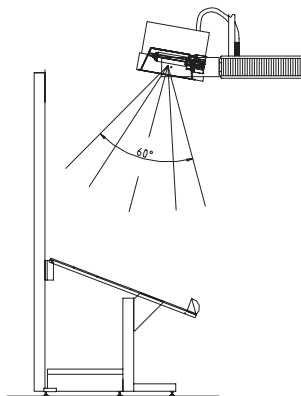
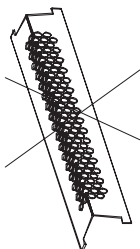
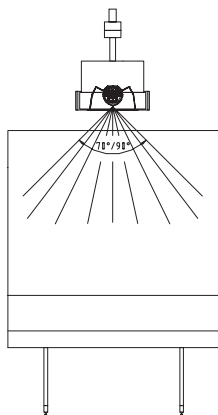

Faro in verticale con fascio luminoso rivolto al corridoio di passaggio e alle scaffalature

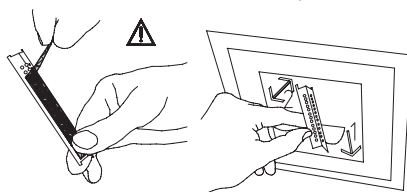
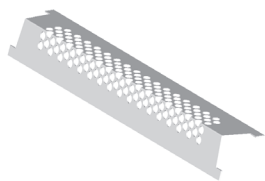
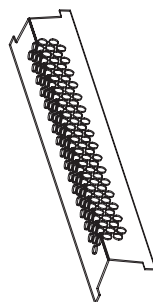
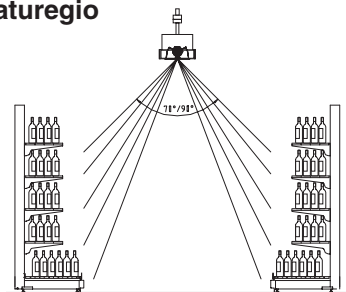

Так как на наши изделия распространяются технические изменения / меры по оптимизации, мы не берем на себя гарантии за то, что все данные соответствуют актуальному состоянию. С вопросами просьба обращаться в наш технический отдел по телефону номер +49 (0)2174 799-0.

Осуществляя эксплуатацию и монтаж светильников, соблюдать указания по технике безопасности.



Важное указание для светильников с лампочками BFL и BBS: при мигании, полном отказе или очень желтом свете (конец срока службы) немедленно отключить светильник и заменить лампочку.

- Подсоединение разрешается проводить только электрику.
 - Проводя монтаж, соблюдать местные предписания.
 - Светильники прошли электромонтаж и готовы к подсоединению:
 - VDE 0711
 - класс защиты I (подключение защитного провода), IP 20
 - Соблюдать сведения, приведенные на приборе Polybox и на светильнике.
 - в процессе эксплуатации лампочка, светильник и прибор Polybox нагреваются.
 - Для встроенных светильников соблюдать свободное пространство как минимум 600 x 500 мм x высота светильника.
 - Не покрывать изоляционным материалом светильник и прибор Polybox.
 - Не ставить друг на друга приборы Polybox.
 - Высокое напряжение на стороне выхода Polybox; опасность для жизни.
 - Если провода прибора Polybox повреждены, необходимо заменить прибор Polybox.
 - Подсоединение приборов Polybox со стороны сети: KVG (BFL 35 Вт, 50 Вт, 100 Вт, BBS 35 Вт, 70 Вт, 150 Вт): 230 В +6% -10%, 50 Гц EVG: 220-240 В, 50/60 Гц
 - В одной цепи тока (с предохранителем В16А) разрешается эксплуатировать не более:
 - BFL 35 Вт, 50 Вт, 100 Вт (KVG) 10 светильников
 - BFL Mini 50 Вт (EVG) 24 светильников
 - BFL Mini 100 Вт (EVG) 14 светильников
 - BBS, CDM-TC 20 / 35 / 70 Вт KVG 10 светильников / EVG 14 светильников
 - BBS 150 Вт KVG 7 светильников / EVG 6 светильников
 - BBS 210 Вт EVG 9 светильников
 - Включаемые реле (контакты) следует подбирать, исходя из коммутационного тока до 50А / 500 мсек
 - Заменять лампочки только тогда, когда светильник отключен от сети.
 - При монтаже или ремонте светильника отключать цепь тока.
 - Соблюдать указания по безопасности, приложенные к лампе.
 - Спустя прикл. 3 - 5 минуты лампочка достигает своего полного светового тока.
 - После отключения или отказа сети лампочке требуется время для охлаждения, прежде чем она опять зажжется. Для охлаждения отсоединить светильник от сети.
 - EVG отключается при тепловой перегрузке, отказе лампы и в конце срока службы лампы.
 - Перед повторным вводом светильника в эксплуатацию необходимо отсоединить EVG от сетевого напряжения. Это правило распространяется и на замену ламп.
 - Соблюдать допустимую нагрузку на перекрытие.
 - Не удалять или изменять распорки на светильнике.
 - Поврежденные провода светильника разрешается заменять только на провода, поставленные заводом-изготовителем.
 - Подсоединять только к подходящим предвключаемым приборам с лампами достаточной мощности.
 - Эксплуатировать светильники BFL Mini (50/100 Вт) только с электронным предвключаемым прибором (EVG).
 - Вывести из эксплуатации светильники BBS, CDM-TC с поврежденным или разбитым стеклом до тех пор, пока не будет заменено стекло. Лампа может лопнуть.
 - Расстояние до облучаемой поверхности (наклейка на рефлекторе):
 - 0,3 м для BFL 35 / 50 / 100 Вт
 - 0,5 м для BBS, CDM-TC 20 / 35 / 70 Вт
 - 1,0 м для BBS 150 Вт
 - 1,5 м для BBS 210 Вт
 - Использовать только допущенные для светильника лампочки. Соблюдать наклейку в рефлекторе или фирменную табличку с параметрами.
 - Указание для 3-фазного режима эксплуатации:
до эксплуатации и во время нее обеспечить, чтобы нейтральный провод надлежащим образом подсоединен ко всем светильникам EVG.
 - Не размещать ничего на светильниках, световых трубках и несущих системах, например, ценники, декоративные элементы.
- KVG: обычный предвключаемый прибор – EVG: электронный предвключаемый прибор

Так как на наши изделия распространяются технические изменения / меры по оптимизации, мы не берем на себя гарантии за то, что все **данные соответствуют актуальному состоянию**. С вопросами просьба **обращаться в наш технический отдел по телефону номер +49 (0)2174 799-0**.

Инструкция по монтажу и эксплуатации

Артикул № Тип светильника

Источник света

Подвесной светильник Pendiro-Delphinus Basic

PENDIRO-DELPHINUS BASIC-MBFL

PENDIRO-DELPHINUS BASIC-MBFL

PENDIRO-DELPHINUS BASIC-BBS

PENDIRO-DELPHINUS BASIC-BBS



BFL Mini - 50 Ватт - GBX12-1

BFL Mini - 100 Ватт - GBX12-1

BBS - 70 Ватт - G12

BBS - 150 Ватт - G12

Подвесной светильник Pendiro-Delphinus Batwing

PENDIRO-DELPHINUS BATWING-MBFL

PENDIRO-DELPHINUS BATWING-BBS

PENDIRO-DELPHINUS BATWING-BBS

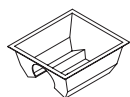

BFL Mini - 100 Ватт - GBX12-1

BLS - 70 Ватт - G12

BLS - 150 Ватт - G12

Подвесной светильник Pendiro-Delphinus Widewing

PENDIRO-DELPHINUS WIDEWING-MBFL

PENDIRO-DELPHINUS WIDEWING-MBFL

PENDIRO-DELPHINUS WIDEWING-BBS

PENDIRO-DELPHINUS WIDEWING-BBS



BFL Mini - 50 Ватт - GBX12-1

BFL Mini - 100 Ватт - GBX12-1

BLS - 70 Ватт - G12

BLS - 150 Ватт - G12

Подвесной светильник
с переходником

Подвесной светильник
с потолочным балдахином

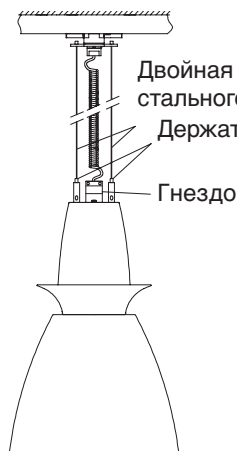

Двойная подвеска из
стального каната

Держатель каната

Гнездо

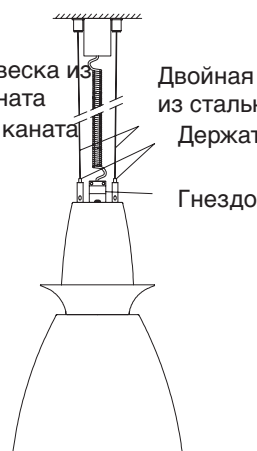

Двойная подвеска
из стального каната

Держатель каната

Гнездо

Монтаж светильника

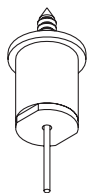

Прочно привинтить держатель каната к светильнику.
Подложить зубчатую шайбу.
Использовать отвертку.

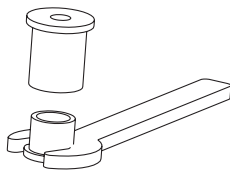

Регулировка светильника по высоте

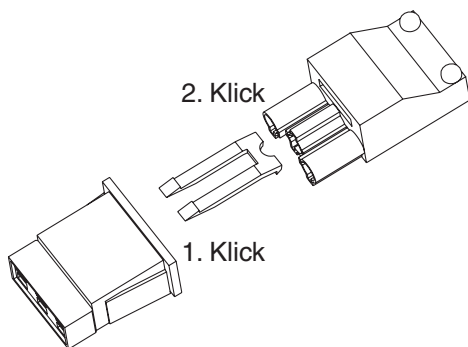
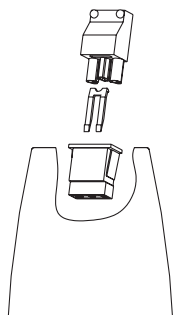
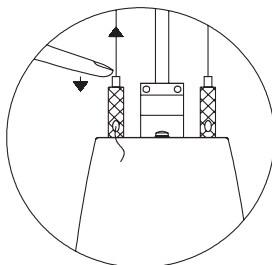

Вставление и замена лампочки:

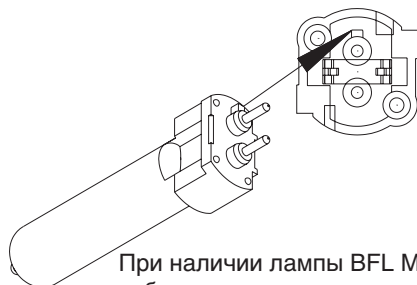
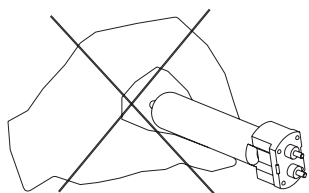
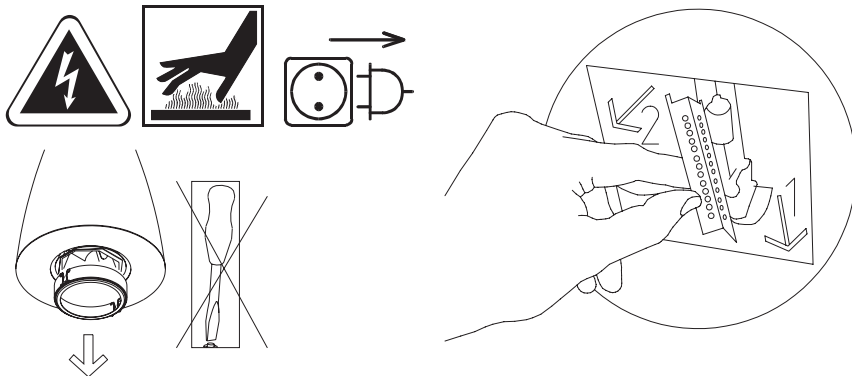

При наличии лампы BFL Mini
соблюдать положение цоколя.

Выправка оси лампы с двойной подвеской из стального каната

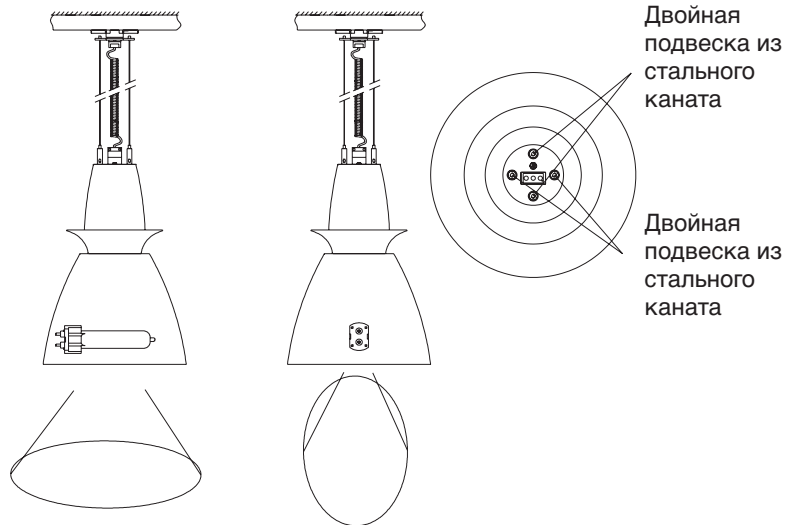

Светильники с ж-образными рефлекторами

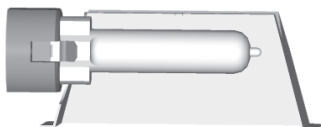

Лампа с размещением поперек к освещаемой поверхности

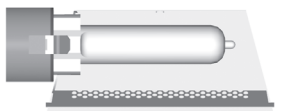
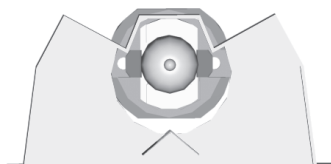
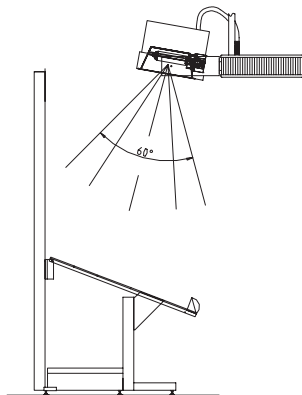
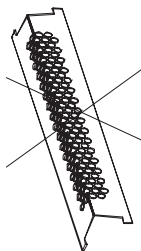
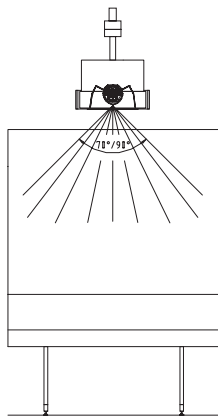

размещением вдоль направления коридоров и полок

