

BÄRO AirWetech L and AirWetech S



The BÄRO AirWetech L and AirWetech S systems have been developed especially for installation in damp environments. Both units work according to the same principle: a powerful fan routes room air through a filter into a UV-C radiation chamber. Here, UV-C emitters give out light with a wavelength of 253.7 nm. This wavelength has a lethal effect on all microorganisms, such as bacteria, moulds yeasts and viruses. The sophisticated construction with integrated air baffles, reflectors and functional check ensures high effectiveness and takes up little space. The UV-C emitters, which produce no ozone, are characterised by a particularly high service life and performance.

Two systems – one solution

Both UV-C moisture-proof disinfection units are constructed according to the same principle and are differentiated solely in terms of per-

formance. For the S variant the tested nominal volume flow is 100 m³/h, whilst the higher power variant L has a nominal volume flow of 200 m³/h.

Data collection

The BÄRO specialists collect the production parameters and calculate the performance and target specifications in conjunction with you. Microbiological measurements carried out by an independent laboratory confirm the excellent reduction of more than 99% of the test bacteria *Bacillus subtilis*.

Tailor-made disinfection

High costs are incurred when producing and storing food due to production errors and produce spoilage. High levels of air moisture, e.g. in cold rooms, stores and in the production of meat products, enhance these effects, or cause them in the first place. BÄRO's tailor-made air disinfection improves air hygiene. This reduces storage costs, there are fewer product returns and the shelf life of your products is increased – an important step in the implementation of hygiene regulations in accordance with European hygiene laws and HACCP.

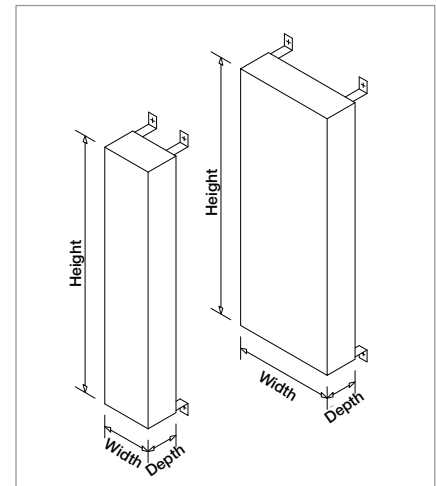

Technical description	UV-C damp location air disinfection unit Air Wetech L	UV-C damp location air disinfection unit Air Wetech S
Product no.	893 495 9999 001	893 295 9999 001
Height (with holder)	1.130 mm (1.240 mm)	1.130 mm (1.240 mm)
Width	440 mm	220 mm
Depth (with holder)	142 mm (215 mm)	142 mm (215 mm)
Supply voltage	230 V ~ 50 Hz	230 V ~ 50 Hz
Power consumption	435 Watt	195 Watt
Filter	Steel mesh filter	Steel mesh filter
Nominal volume flow	200 m ³ /h	100 m ³ /h
Noise development	54 db (A)	46 db (A)
UV-C emitters	4 x 95 Watt	2 x 95 Watt
UV-C output	128 W	64 W
Emitter service life	8.000 h	8.000 h
Protection class	I	I
Protection rating	IP 54	IP 54
Material	Polished stainless steel; 1.4301	Polished stainless steel; 1.4301
Attachment	4 mounting brackets	4 mounting brackets
Weight	29 kg	18 kg

Description	Roller base for Air Wetech L	Roller base for Air Wetech S
Product no.	893 495 9999 050	893 295 9999 050
Height	155 mm	155 mm
Width	540 mm	455 mm
Depth	510 mm	435 mm
Design	5 casters, 2 lockable	5 casters, 2 lockable
Material	Steel, powder-coated RAL 9005	Steel, powder-coated RAL 9005
Weight	9.0 kg	7.6 kg

BÄRO
AIR HYGIENE

www.baero.com